

# CASIO®

# Service Manual

(with price)

## GZ-5

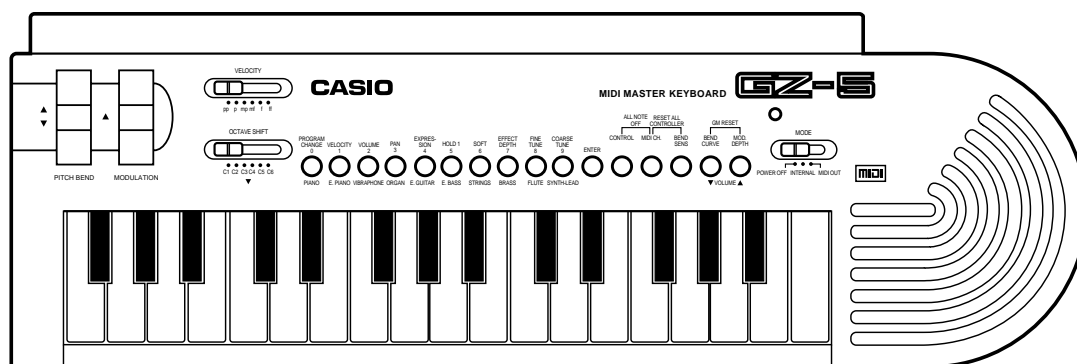

GZ-5

### MIDI MASTER KEYBOARD

**INDEX**

# CONTENTS

Specifications .....	2
Operation .....	3
Block Diagram .....	8
Circuit Description .....	9
Schematic Diagrams .....	10
Exploded View .....	12
Parts List .....	13

## SPECIFICATIONS

### GENERAL (Internal Mode)

Number of Keys:	32
Polyphonic:	4-note
Preset Tones:	10; Piano, E. Piano, Vibraphone, Organ, E. Guitar, E. Bass, Strings, Brass, Flute, Synth-Lead
Controls:	Volume control; 5 levels, Pitch bend switch, Modulation switch
Built-In Speaker:	6.5 cm dia. 0.5 W input rating: 1 pec.
Tuning:	A4=442 Hz (fixed)
Terminals:	MIDI Output, AC Adapter Jack (DV 7.5 V)
Power Source:	DC: 4 AA size dry batteries Battery life: Approx. 6 hours (SUM-3/R6P) AC: AC Adapter AD-1
Power Consumption:	0.7 W when operating by batteries 1.0 W when operating by an AC adapter
Dimensions (HWD):	50 x 399 x 132 mm (1-15/16 x 15-11/16 x 5-3/16 inches)
Weight:	0.64 kg (1.4 lbs) including batteries

### ELECTRICAL

Current Drain with 7.5 V DC:	
No Sound Output	35 mA $\pm$ 20%
Maximum Volume	103 mA $\pm$ 20%
with keys A2, B2, C3 and D3 pressed	
in Synth-Lead tone, Volume: Maximum	
Speaker Output Level at 10 cm away from the speaker	690 mV $\pm$ 20%
with key C3 pressed in Synth-Lead tone	
Volume: Maximum	
Minimum Operating Voltage:	4.8 V

# OPERATION

## Transmitting MIDI Messages

To transmit MIDI messages, set the Mode Switch to the MIDI OUT position.

### Operation 1

The note number is transmitted when the corresponding key is pressed.

Use the Octave Shift Switch, and select the position appropriate to the octave range you want. GZ-5 can send note numbers 17 to 108 but it has 32 keys only.

Velocity is also transmitted when a key is pressed. GZ-5 sends the velocity in accordance with the selected position of the velocity switch.

Data of pitch bend and modulation is transmitted when the corresponding switch is operated.

The values of the velocity, the pitch bend and the modulation switches are automatically set up to the initial value when turning on the power.

See the appendix for information about the initial value.

See the following table for instruction how to change the value.

MIDI Message	Operation switch	Setting	Operation for setting
Note No.	Keyboard Octave shift switch	Octave range	See the figure below
Velocity	Keyboard Velocity switch	Velocity value	CONTROL + VELOCITY, XXX, ENTER
Pitch Bend	Pitch bend switch	Bend sense Bend curve	BEND SENS, XXX, ENTER BEND CURVE, X, ENTER
Modulation	Modulation switch	Modulation depth	MOD.DEPTH, XXX, ENTER

Example of operation : CONTROL + VELOCITY, XXX, ENTER  
 Press CONTROL button and VELOCITY button at the same time.  
 Use the 10-key pads, enter a 3-digit number.  
 Press ENTER button.

Position of the octave switch and octave range

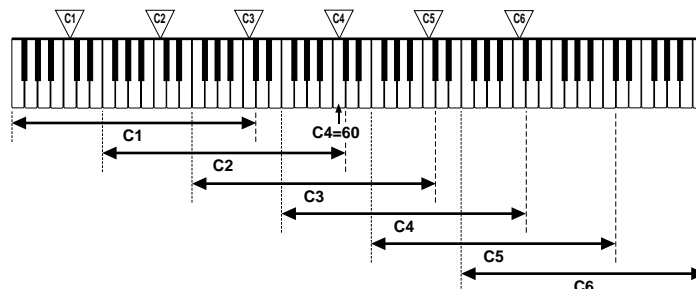

## Operation 2

The MIDI messages listed below are transmitted when completing the operation shown in the following table.

MIDI Message	Operation
Program change	CONTROL + PROGRAM CHANGE, XXX, ENTER
Control change      Volume	CONTROL + VOLUME, XXX, ENTER
Pan	CONTROL + PAN, XXX, ENTER
Expression	CONTROL + EXPRESSION, XXX, ENTER
Hold 1	CONTROL + HOLD 1, XXX, ENTER
Soft pedal	CONTROL + SOFT PEDAL, XXX, ENTER
Effect depth	CONTROL + EFFECT DEPTH, XXX, ENTER
Fine tune	CONTROL + FINE TUNE, XXX, ENTER
Coarse tune	CONTROL + COARSE TUNE, XXX ENTER
All notes off	CONTROL + MIDI CH.
Reset all controller	MIDI CH. + BEND SENSE
General MIDI reset	BEND CURVE + MOD. DEPTH
MIDI channel	MIDI CH., XXX, ENTER

Example of operation :   CONTROL + VELOCITY, XXX, ENTER  
 Press CONTROL button and VELOCITY button at the same time.  
 Use the 10-key pads, enter a 3-digit number.  
 Press ENTER button.

Notes: 1. See the appendix for information about a value to be entered, "XXX".  
 2. For details of MIDI message and operation, see GZ-5 operation manual.

## Initial Value/Setting Range

Internal Mode	Initial Setting	Setting Range
Tone	Piano	Piano, E. Piano, Vibraphone, Organ, E.Guitar, E.Bass, Strings, Brass, Flute, Synth-Lead
Bend Sens	2	0 - 3
Volume	Max.	5 levels

MIDI Out Mode	Initial Setting	Setting Range
Control		
Program Change	—	0 - 127
Velocity	—	1 - 127
Volume	—	0 - 127
Pan	—	0 - 127
Expression	—	0 - 127
Hold 1	—	0 - 127
Soft	—	0 - 127
Effect Depth	—	0 - 127
Fine Tune	—	0 - 127
Coarse Tune	—	0 - 127
Velocity	mf (95)	pp (50), p (70), mp (85), mf (95), f (110), ff (127)
Octave Shift	C4	C1, C2, C3, C4, C5, C6
Vend Sense	—	0 - 127
Bend Curve	1 (Approx. 0.096 sec)	0 (approx. 0.048 sec.), 1 (approx. 0.096 sec) 2 (approx. 0.192 sec.), 3 (approx. 0.384 sec.) 4 (approx. 0.768 sec.)
Modulation Depth	127	0 - 127
MIDI Channel	1	1 - 16

## MIDI Transmission

<b>Program Change</b> 0 - 127	
<b>Note ON/OFF</b>	
Note No.:	F0 - C8 (17 - 108)
Velocity:	1 - 127 Note ON 0 Note OFF
<b>Pitch Bend:</b> 0 - 16383 (14 bits)	
<b>Control Change</b>	
Modulation	Controller No.: 1 Controller Value: 0 - 127
Volume	Controller No.: 7 Controller Value: 0 - 127
PAN	Controller No.: 10 Controller Value: 0 - 127
Expression	Controller No.: 11 Controller Value: 0 - 127
HOLD 1	Controller No.: 64 Controller Value: 0 - 127
Soft Pedal	Controller No.: 67 Controller Value: 0 - 127
External Effect Depth	Controller No.: 91 Controller Value: 0 - 127

<b>Registered Parameter Number</b>	
Pitch Bend Sensitivity	
RPN LSB (100):	0
RPN MSB (101):	0
Data Entry MSB (6):	0 - 127
Data Entry LSB (38):	0
Fine Tune	
RPN LSB (100):	1
RPN MSB (101):	0
Data Entry MSB (6):	0 - 127
Data Entry LSB (38):	0
Coarse Tune	
RPN LSB (100):	2
RPN MSB (101):	0
Data Entry MSB (6):	0 - 127
Data Entry LSB (38):	0
<b>Channel Mode Message</b>	
Reset All Controller	
Controller No.:	121
Controller Value:	0
All Note Off	
Controller No.:	123
Controller Value:	0
<b>System Exclusive Message</b>	
GM ON	
[F0] [7E] [7F] [09] [01] [F7]	

## Note Range of Keyboard Play

Tone	Range
PIANO	F3 - C6
E.PIANO	F3 - C6
VIBRAPHONE	F3 - C6
ORGAN	F3 - C6
E.GUITAR	F4 - C7

Tone	Range
E.BASS	F2 - C5
STRINGS	F3 - C6
BRASS	F3 - C6
FLUTE	F3 - C6
SYNTH-LEAD	F3 - C6

# MIDI Implementation Chart

Version: 1.0

Function ...	Transmitted	Recognized	Remarks
<b>Basic Channel</b> <b>Default Changed</b>	1 channel 1-16 channel	X X	
<b>Mode</b> <b>Default Messages Altered</b>	— X *****	X X *****	
<b>Note Number:</b> <b>True voice</b>	17 ~ 108 *****	X *****	
<b>Velocity</b> <b>Note ON</b> <b>Note OFF</b>	○ 9nH v = 1~127 X 9nH v = 0, 8nH v = **	X X	** = No relation
<b>After Touch</b> <b>Key's Ch's</b>	X X	X X	
<b>Pitch Bender</b>	○	X	
<b>Control Change</b> <b>01</b> <b>06, 38</b> <b>07</b> <b>10</b> <b>11</b> <b>64</b> <b>67</b> <b>91</b> <b>100, 101</b> <b>121</b>	○ ○ *1 ○ ○ ○ ○ ○ ○ ○ *1 ○	X X X X X X X X X X	Modulation Data entry Volume PAN Expression Hold 1 Soft External effect depth RPN LSB • MSB Reset all controller
<b>Program Change</b> <b>: True #</b>	○ 0 ~ 127 *****	X *****	
<b>System Exclusive</b>	○ *2	X	*2 : GM On
<b>System Common</b> <b>: Song Pos</b> <b>: Song Sel</b> <b>: Tune</b>	X X X	X X X	
<b>System Real Time</b> <b>: Clock</b> <b>: Commands</b>	X X	X X	
<b>Aux Messages</b> <b>: Local ON/OFF</b> <b>: All notes OFF</b> <b>: Active Sense</b> <b>: Reset</b>	X ○ X X	X X X X	
<b>Remarks</b>	*1: Pitch Bend Sens                      *2 : GM On Fine Tune                                      [F0] [7E] [7F] [09] [01] [F7] Coarse Tune		

Mode 1 : OMNI ON, POLY  
Mode 3 : OMNI OFF, POLY

Mode 2 : OMNI ON, MONO  
Mode 4 : OMNI OFF, MONO

○ : Yes  
X : No

## BLOCK DIAGRAM

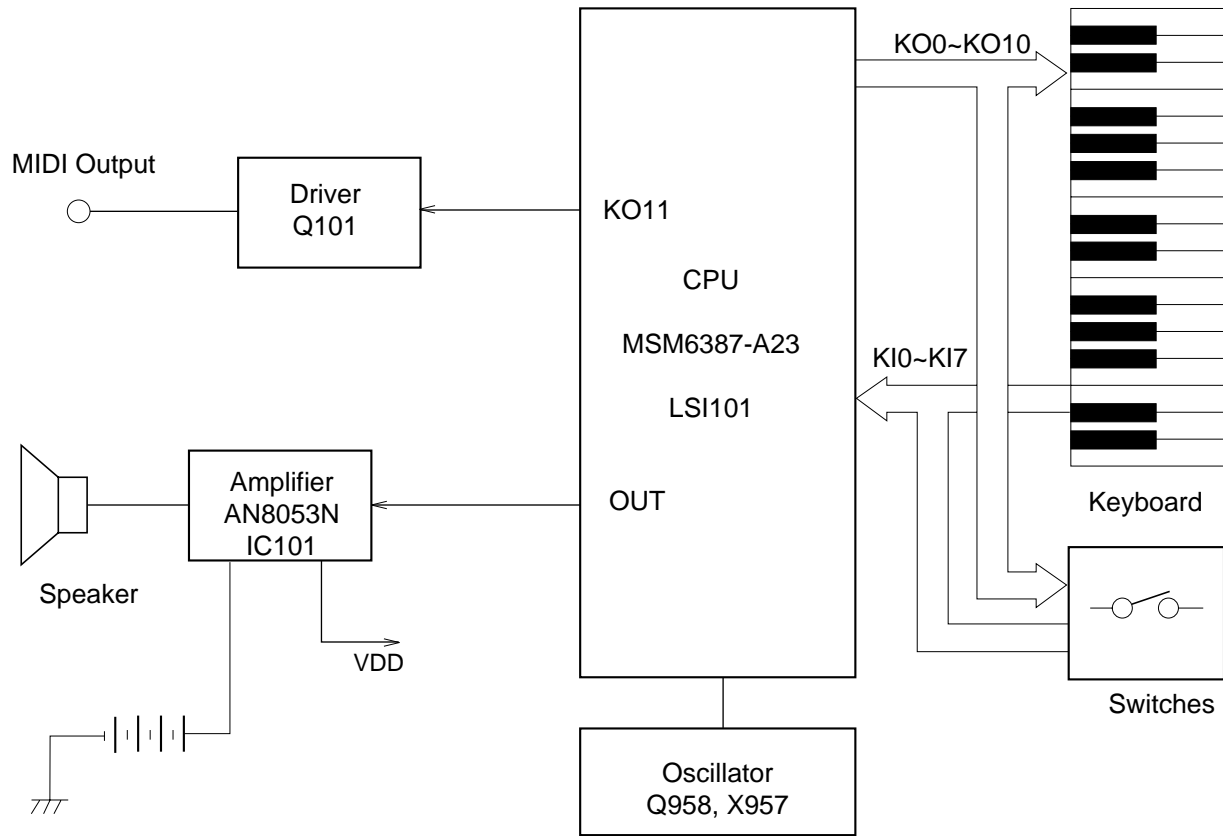

## Nomenclature of Keys

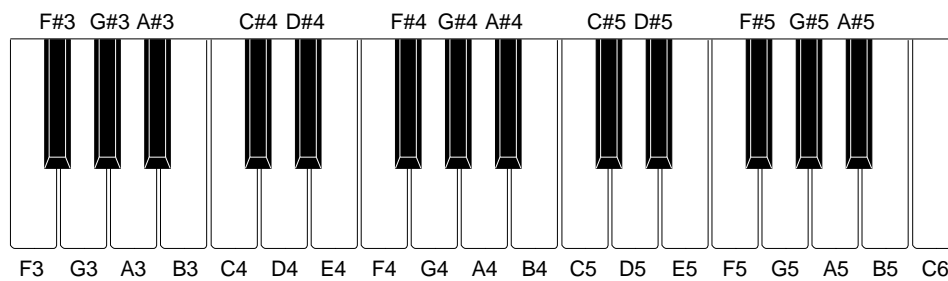



## CIRCUIT DESCRIPTION

### Key Matrix

	KI0	KI1	KI2	KI3	KI4	KI5	KI6	KI7
KO0	F3	F#3	G3	G#3	A3	A#3	B3	C4
KO1	C#4	D4	D#4	E4	F4	F#4	G4	G#4
KO2	A4	A#4	B4	C5	C#5	D5	D#5	E5
KO3	F5	F#5	G5	G#5	A5	A#5	B5	C6
KO4				Pad 0	Pad 1	Pad 2	Pad 3	Pad 4
KO5			Enter	Pad 5	Pad 6	Pad 7	Pad 8	Pad 9
KO6				Volume Up	Volume Down	Bend Sense	MIDI CH.	Control
KO7	Pitch Bend -							Pitch Bend +
KO8								Modulation
KO9			Velocity ff	Velocity f	Velocity mf	Velocity mp	Velocity p	Velocity pp
KO10	Internal	MIDI Out	Octave Shift C6	Octave Shift C5	Octave Shift C4	Octave Shift C3	Octave Shift C2	Octave Shift C1

### CPU (LSI101: MSM6387-A23)

Containing a MIDI controller, the CPU outputs MIDI messages in accordance with the pressed keys and buttons.

The following table shows the pin functions of LSI101.

Pin No.	Terminal	In/ Out	Function
1, 2	TEST1, TEST2	—	Not used. Connected to ground.
3	RESET	In	Power ON reset input. On: +6V Off: 0V
4	AVDD	In	+5 V source for the built-in DAC
5	OUT	Out	Sound waveform output
6	AGND	In	Ground (0 V) source for the built-in DAC
7	GND	In	Ground (0 V) source
8	COSI	In	21.725 MHz clock pulse input
9	COSO	—	Not used.
10	VDD	In	+5 V source
11 ~ 18	KI0 ~ KI7	In	Input terminal from keys and switches
19	KO11	Out	MIDI signal output
20 ~ 30	KO10 ~ KO0	Out	Key and switch scan signal output

# SCHEMATIC DIAGRAMS

## JCMCLK1-CL1M

**f=21.725MHz**

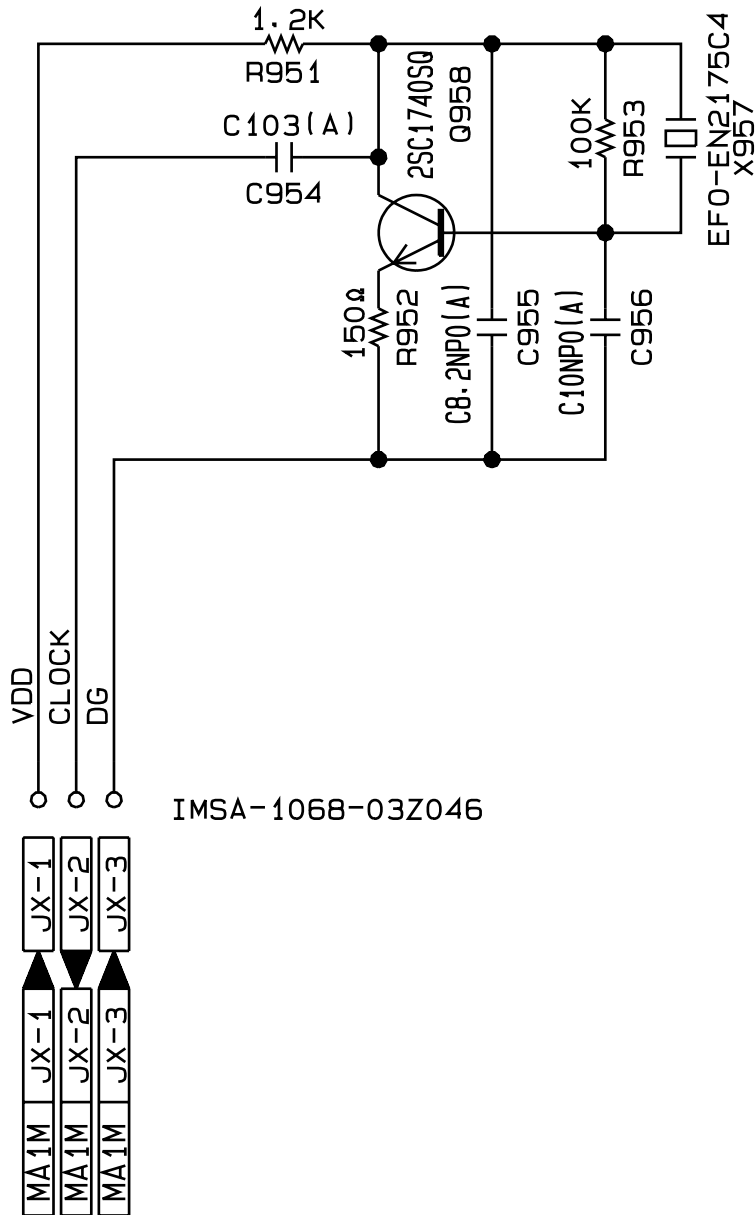

Main PCB JCM558-MA1M

**NOTE**

- EXC-ELDR35V-T
- 1SS133T-77-T
- ◇ ○ VOLTAGE CHECK POINT

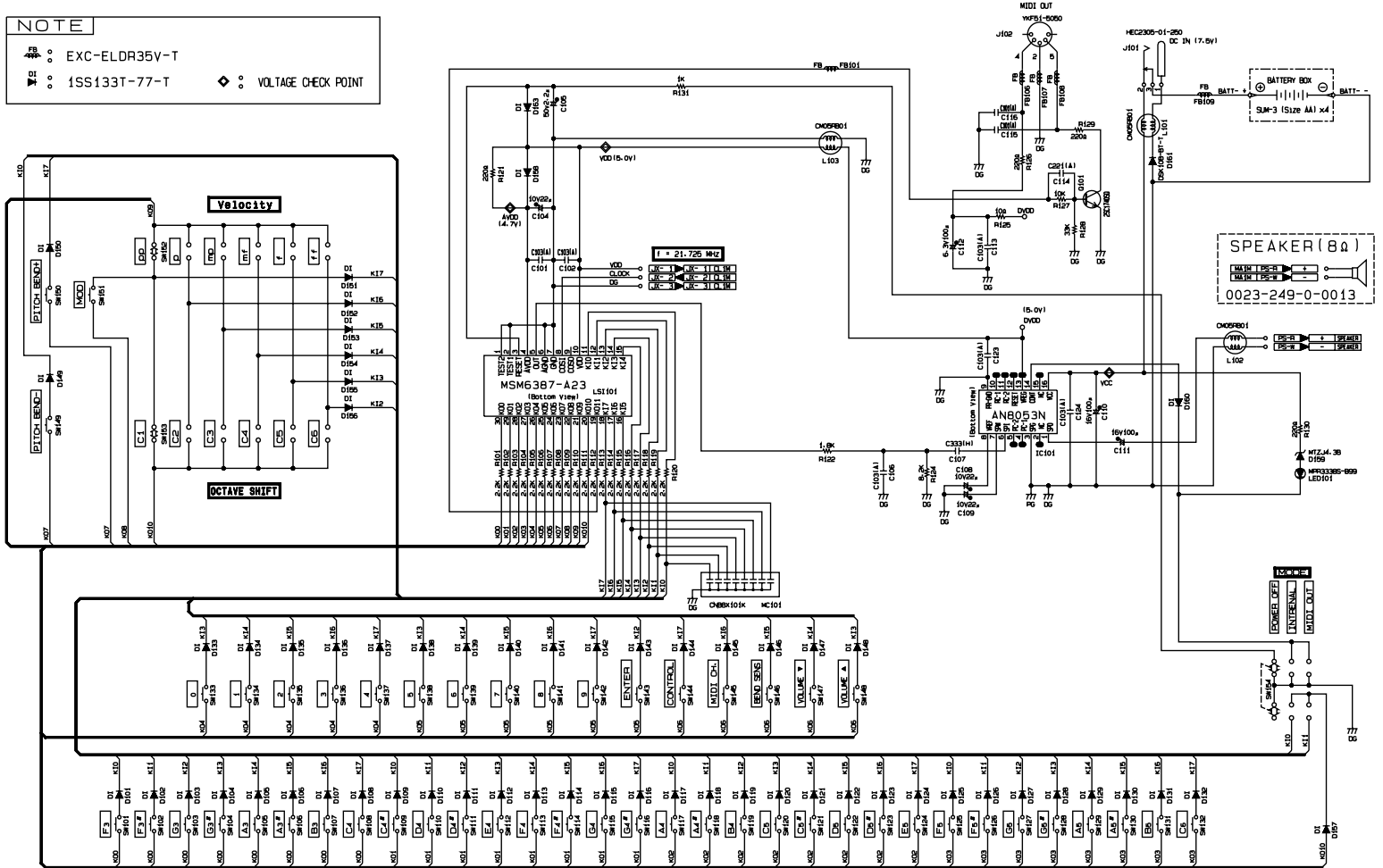

# EXPLODED VIEW

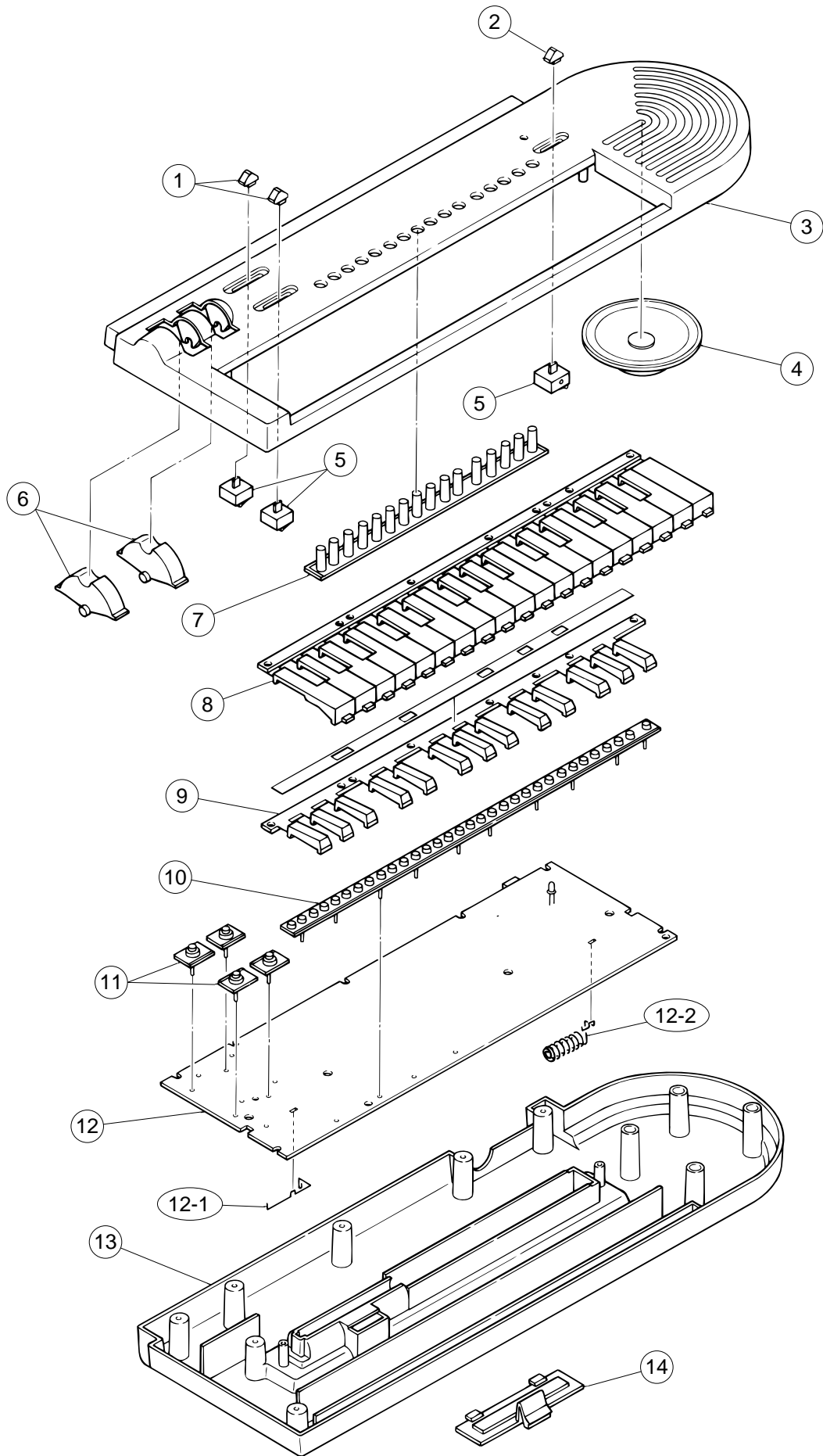

# PARTS LIST

## GZ-5

- Notes:
1. Prices and specifications are subject to change without prior notice.
  2. As for spare parts order and supply, refer to the "GUIDEBOOK for Spare parts Supply", published separately.
  3. The numbers in item column correspond to the same numbers in drawing.

N	Item	Code No.	Parts Name	Specification	Q	FOB Japan N.R.Yen Unit Price	R
<b>Electrical Parts</b>							
N	12	6923 6680	PCB ass'y JCM558-MA1M	M240209*1	1	1,650	B
N	LSI101	2012 0196	LSI	MSM6387-A23	1	430	A
	IC101	2114 3269	IC	AN8053N	1	110	A
	Q101	2220 1387	Transistor	2SC1740SQ-TP-T	1	13	B
	Q958	2220 1387	Transistor	2SC1740SQ-TP-T	1	13	B
	X959	2590 1897	Ceramic oscillator	EFO-EN2175C4	1	60	B
	D101~D158, D160, D163	2390 1344	Diode	1SS133T-77-T	60	3	B
	D159	2360 2429	Zener diode	MTZJ4.3B-T77-T	1	8	B
	D161	2390 0371	Diode	DSK10B-BT-T	1	11	B
	LED101	2370 1106	LED	MPR3338S-B99	1	24	B
	J101	3501 3731	Power jack	HEC2305-01-250	1	30	B
N	J102	3501 4830	DIN jack	YKF51-5050	1	70	B
	12-1	6917 1762	Battery spring (+)	M410913B-1	1	5	C
	12-2	6922 1760	Battery spring (-)	M412226-1	1	10	C
<b>Mechanical Parts</b>							
N	1	6906 7751	Slide knob, Gray	M311859A-3	2	12	B
N	2	6906 7761	Slide knob, Purple	M311859A-4	1	12	B
N	3	6923 9070	Upper case sub ass'y	M340288*1	1	570	C
N	4	3831 0812	Speaker	0023-249-0-0013	1	150	B
	5	6909 5890	Slide contact	CSB-12D	3	35	B
N	6	6923 6740	Bender knob	M340143-1	2	80	C
N	7	6923 6730	Rubber button	M340142-1	1	200	C
	8	6917 1571	White key set	M210610A-1	1	69	A
	9	6917 1580	Black key set	M210609-1	1	41	A
	10	6917 1591	Key contact rubber	M210605A-1	1	80	A
N	11	6923 6750	Button contact rubber	M340144-1	4	15	B
N	13	6923 9060	Lower case sub ass'y	M340287*1	1	450	C
N	14	6906 7931	Battery cover	M312197A*6	1	35	B

Notes: N – New parts  
M – Minimum order/supply quantity  
R – Rank

**CASIO COMPUTER CO.,LTD.**  
Service Division

8-11-10, Nishi-Shinjuku  
Shinjuku-ku, Tokyo 160, Japan  
Telephone: 03-3347-4926

MA0700951A